

EXAMPLE CONNECTIONS

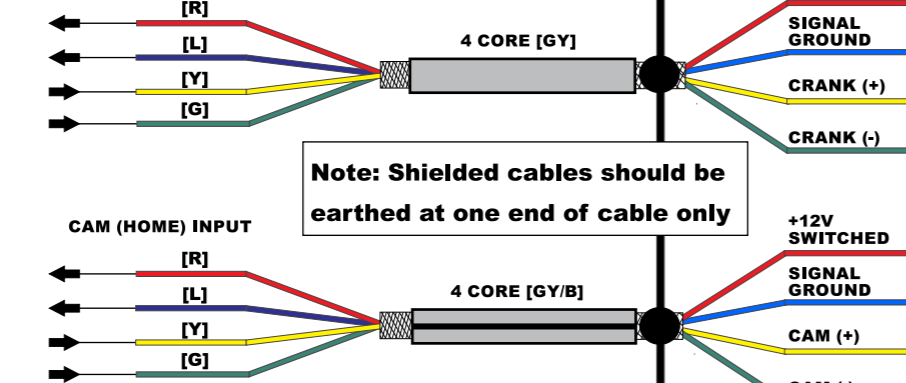

Note: Shielded cables should be earthed at one end of cable only

MAIN HARNESS CAN CONNECTOR

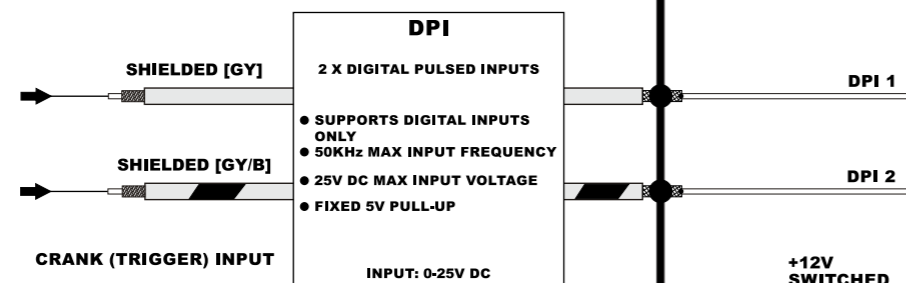
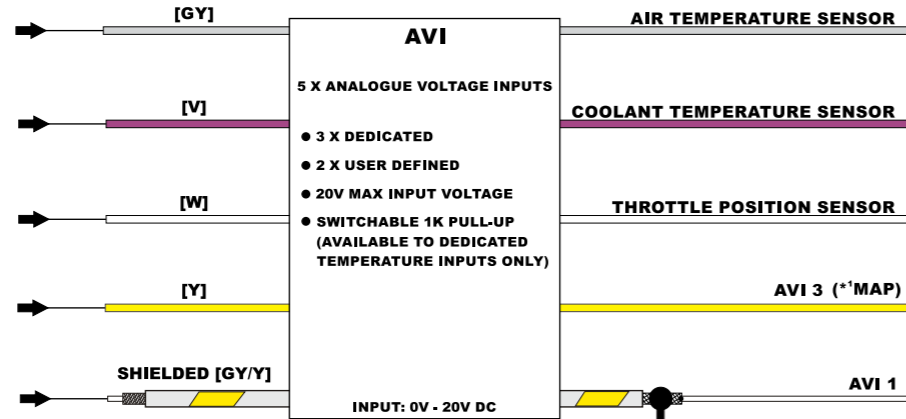
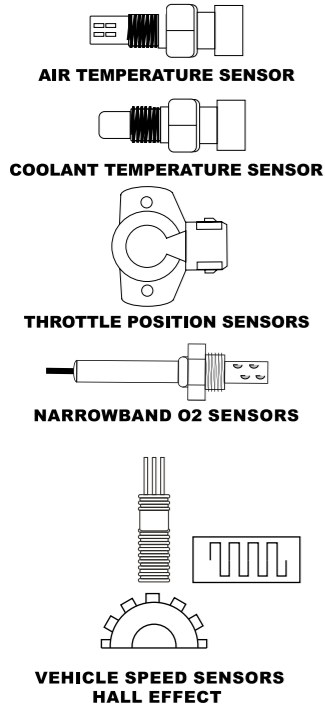
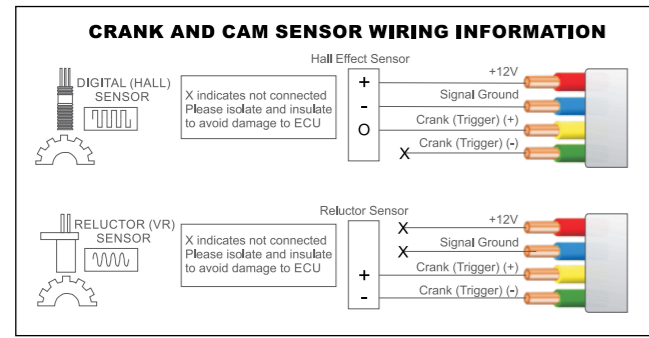
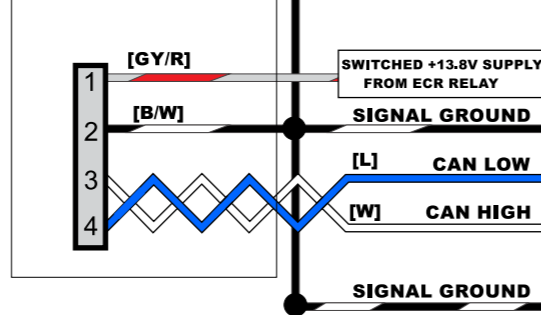

LOOKING INTO CONNECTOR ON ECU

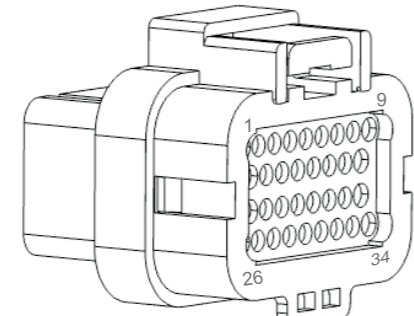
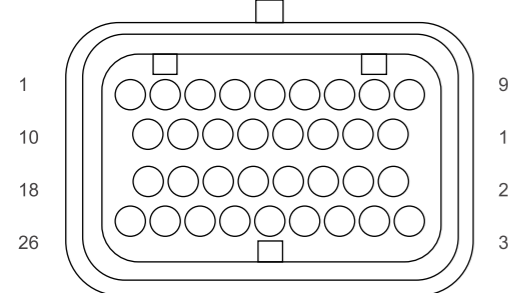

34 PIN CONNECTOR

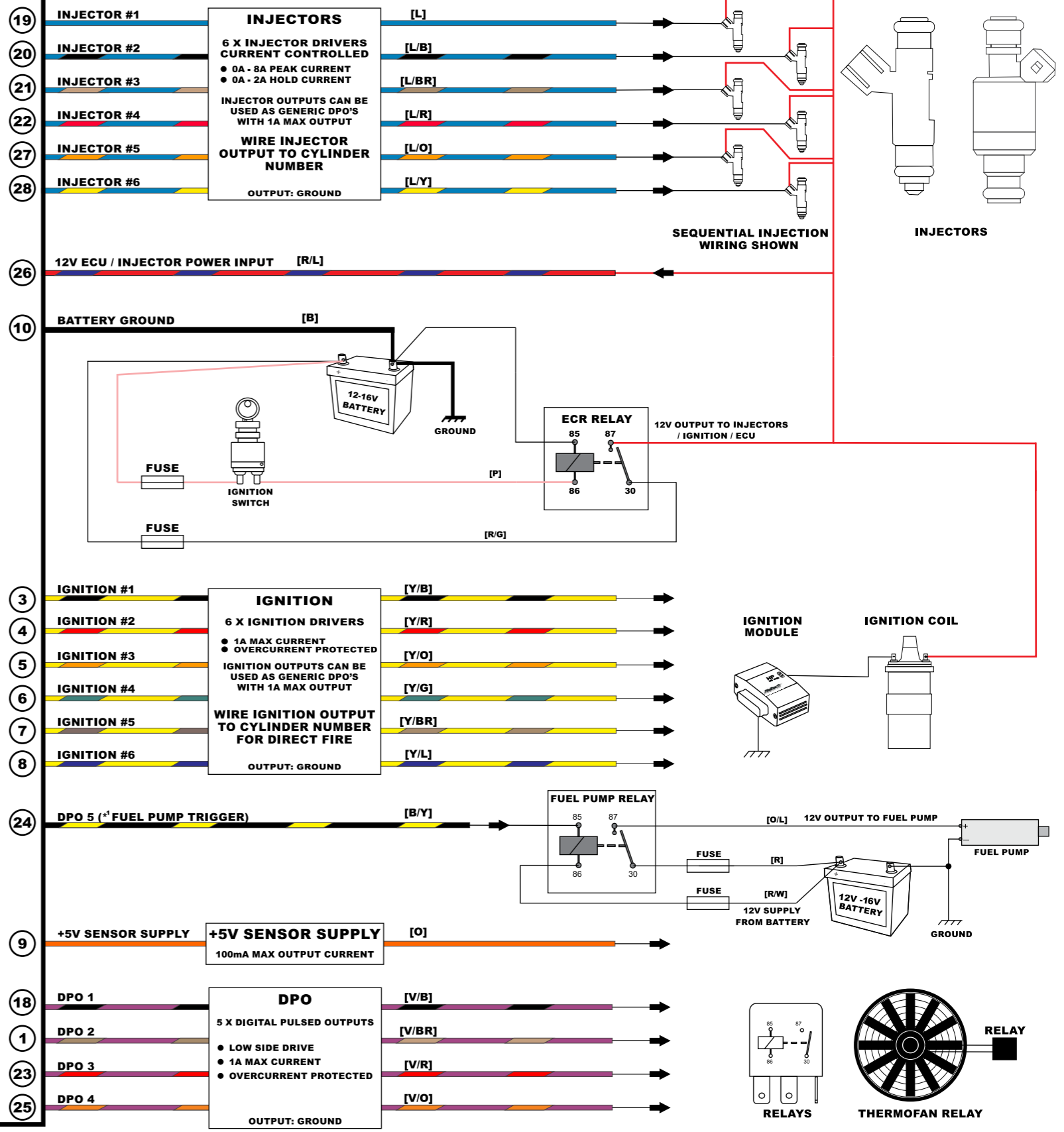

LEGEND - WIRE COLOUR
 B = BLACK BR = BROWN G = GREEN GY = GREY L = BLUE
 O = ORANGE P = PINK R = RED V = VIOLET Y = YELLOW W = WHITE
 WHEN TWO COLOURS ARE USED IN A WIRE BY THE ALPHABETICAL CODE,
 THE FIRST LETTER INDICATES THE BASIC WIRE COLOUR,
 THE SECOND COLOUR INDICATES THE COLOUR OF THE STRIPE.

NOTES:
 *1 RECOMMENDED FUNCTION ALLOCATION,
 BUT NOT LIMITED TO